

CSE 2021 COMPUTER ORGANIZATION

HUGH CHESSER
CSE B 1012U

Pipelining with Single Cycle Datapath (2)

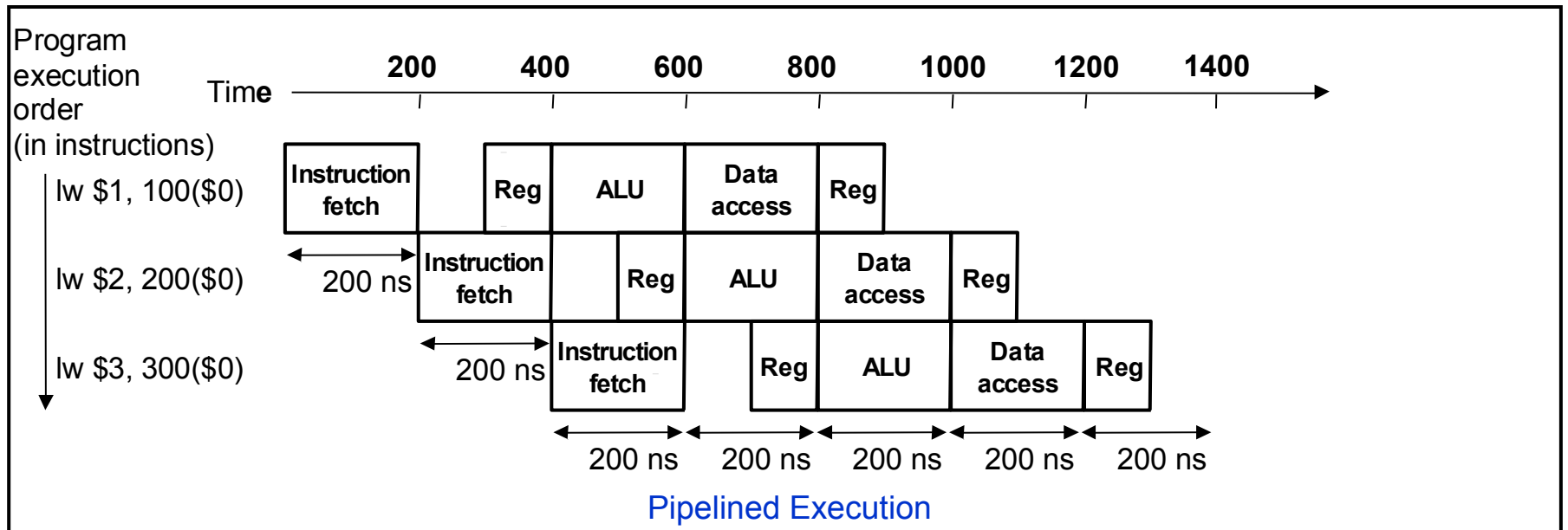
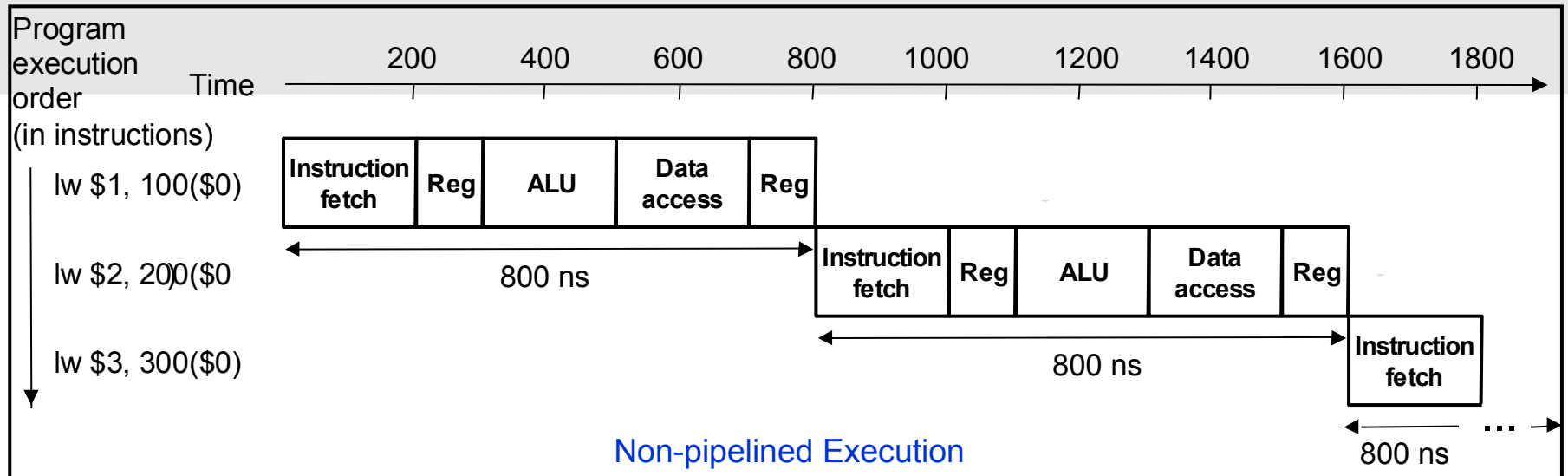

Pipelining with Single Cycle Datapath (3)

- Speedup obtained through pipelining equals the number of pipe stages if execution time of each stage is the same.
- In our previous example, speedup should be 5.

Actual speedup in our previous example = $2400 / 1400 = 1.71$

Why? Number of instructions are too small.

Increase the number of instructions to 1003.

Then speedup = $(1003 \times 800) / (200 \times 1003 + 800) = 802400 / 201400 = 3.98$

- Pipelining added some overhead (additional 100ps for Register read)
- Note that pipelining increases the overall throughput. The execution time for each instruction stays the same.

Graphical Representation

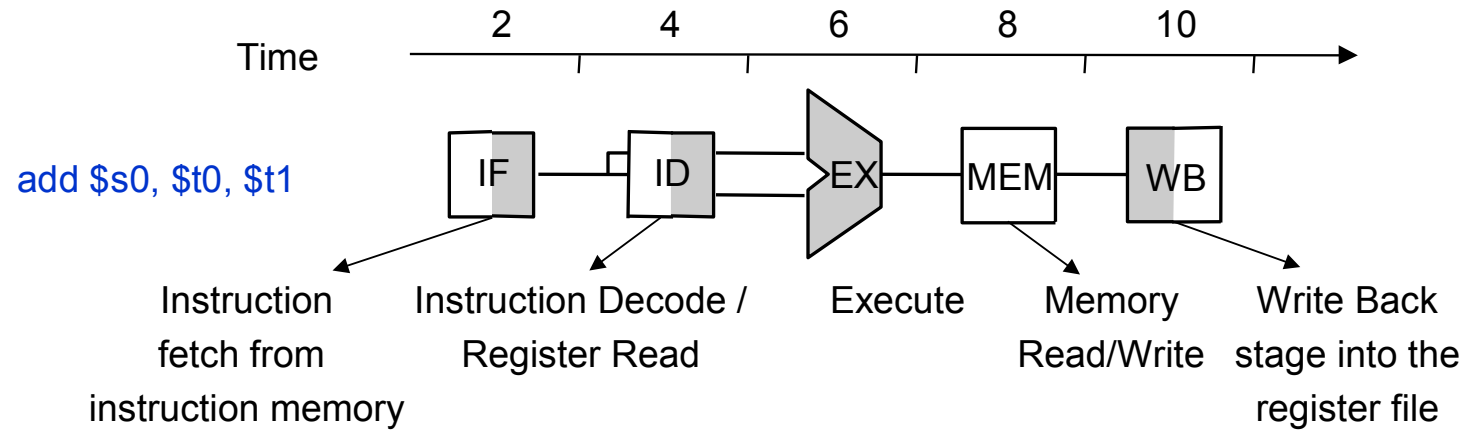

1. Shading in each block indicates what the element is used for in the instruction.
2. Shading on the left half of the block indicates that the element is being written. During instruction fetch, the instruction memory is read so the right half of IF block is shaded.
3. Shading on the right half of the block indicates that the element is being read. During write back stage, the register file is written so the left half of the WB block is shaded.

Activity 2

Using the graphical representation, show that the following swap procedure has a pipeline hazard. Reorder the instructions to avoid pipeline stalls.

```
lw $t0, 0($t1)
lw $t2, 4($t1)
sw $t2, 0($t1)
sw $t0, 4($t1)
```

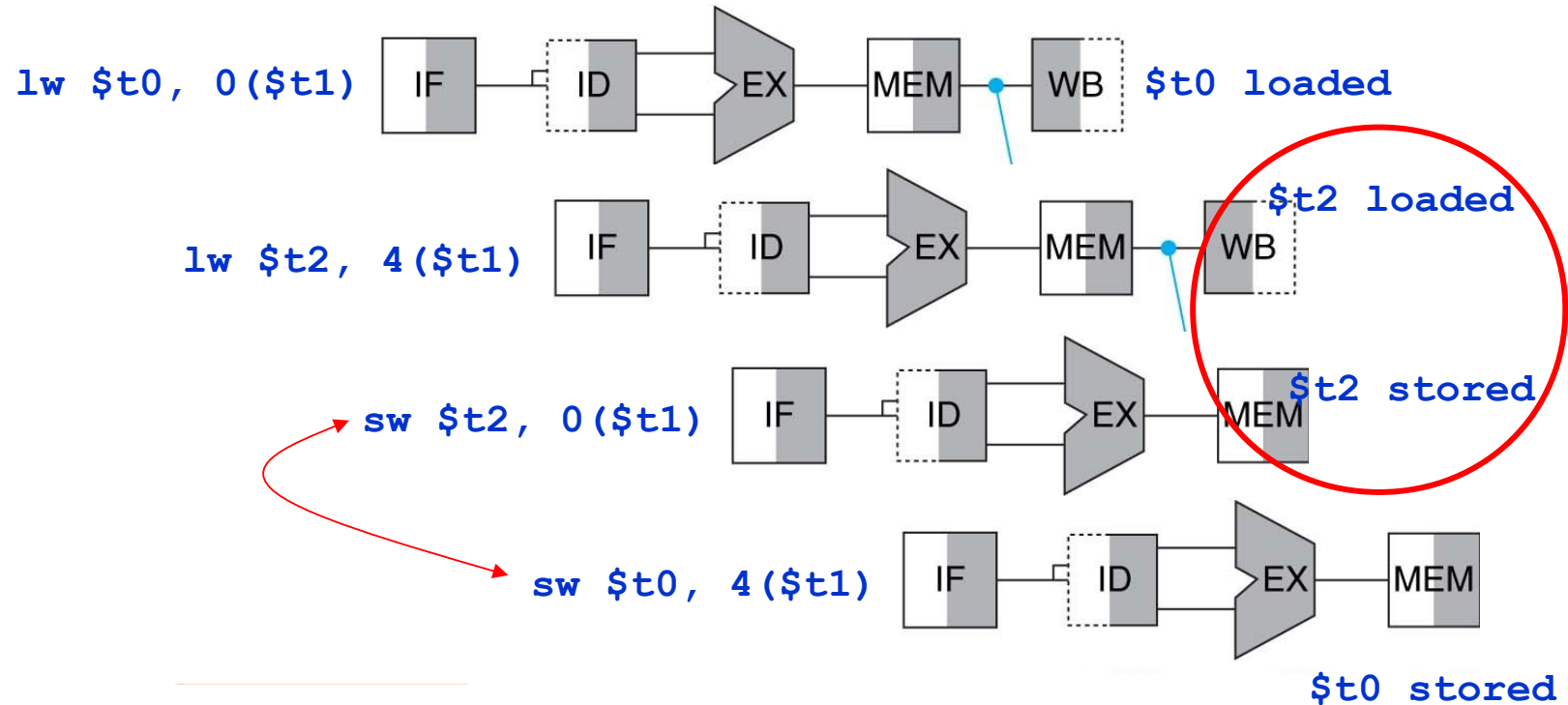

Agenda

Topics:

1. Pipeline Datapath and Control

Patterson: 4.5

Pipelined Datapath (1)

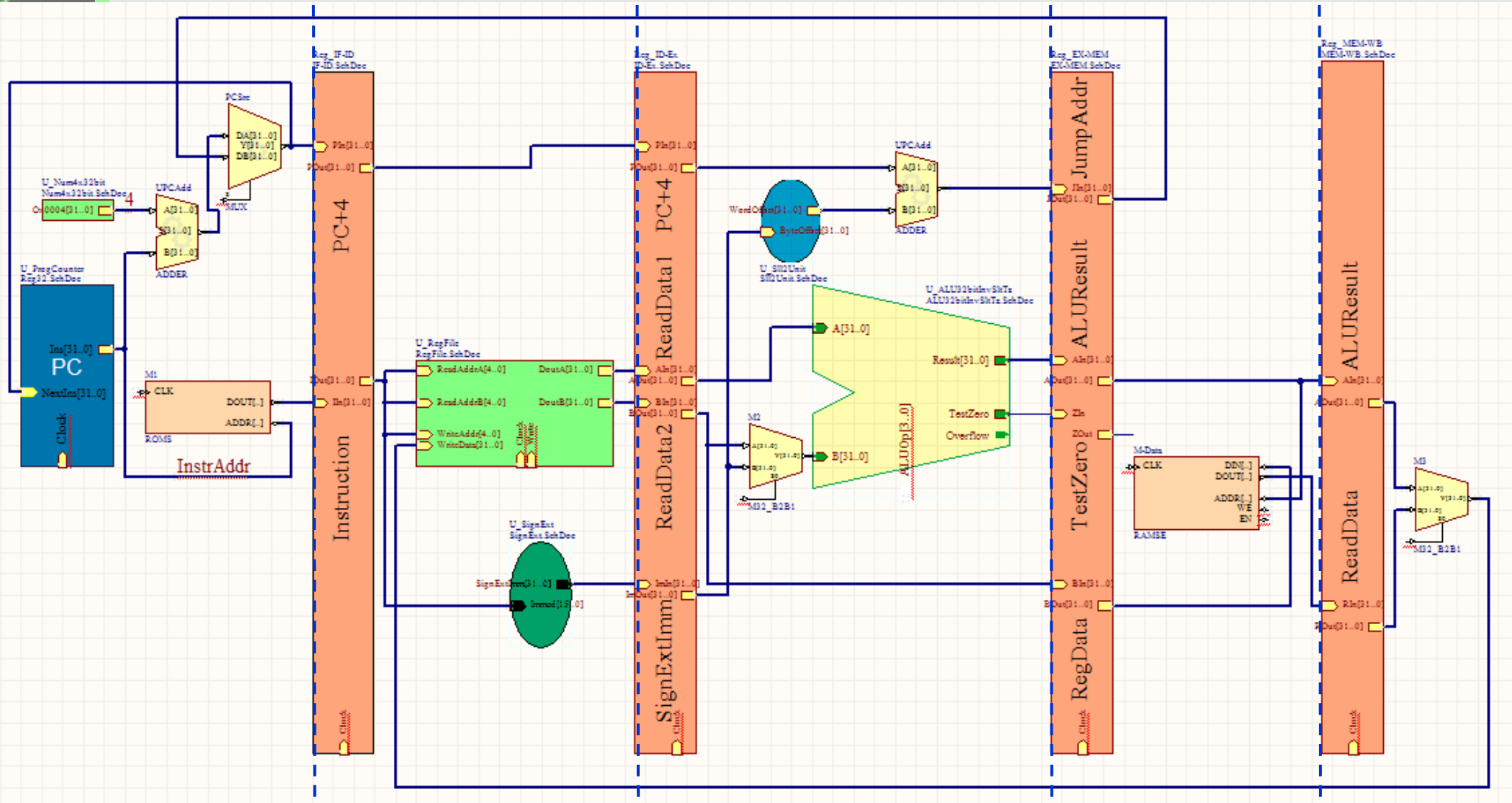

IF: Instruction Fetch

ID: Instruction Decode /
Register file read

EX: Execute /
Address Calculation

MEM: Memory
Access

WB: Write
back

will-w

?

Pipelined Datapath (2)

- In pipelined datapath, each instruction is broken in five steps:
IF (Instruction Fetch), ID (Instruction Decode and register file read), EX (Execution or address calculation), MEM (Data Memory Access), and WB (Write Back).
- Each of the above step takes one clock cycle.
- Instructions and data advance forward by from left to right.
- Data flows from right to left only in two cases
 1. Write back stage placing the data in the register file
 2. Selection of the value for PC between $(PC + 4)$ and branch target address
- Registers in between different stages store the store values to be used by next stage
- Name of registers are based on the two pipelined stages that the registers separate
- Each pipelining register has a different size: IF/ID register is 64 bits wide; ID/EX register is 128 bits wide; EX/MEM register is 97 bits wide; and MEM/WB is 64 bits wide
- There are no pipeline registers at the end of the write-back stage as data is written directly into memory or register file or the PC.

How pipelining works (1): Example `lw $s1, 0($s2)`

Datapath for Instruction Fetch (IF)

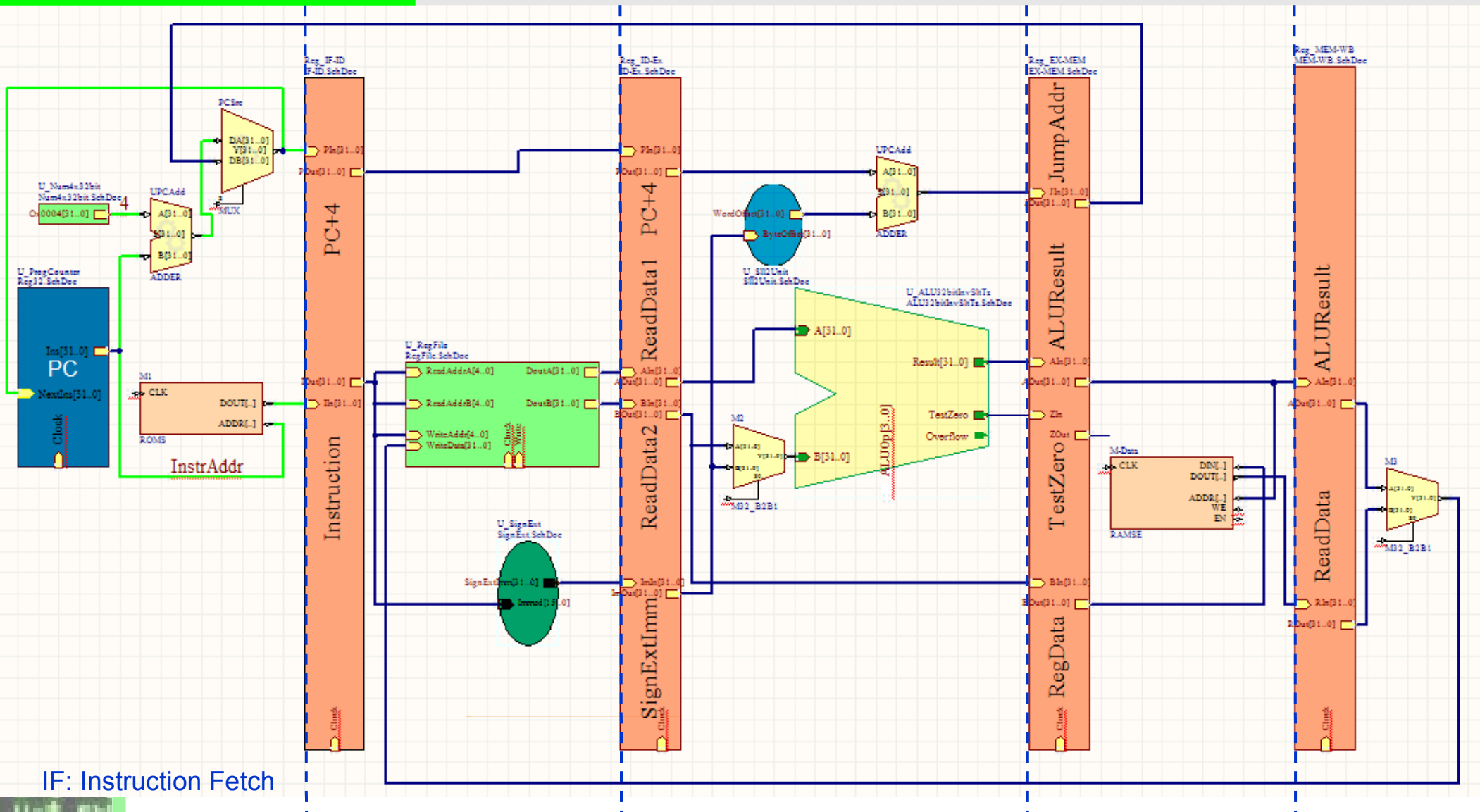

IF: Instruction Fetch

How pipelining works (2): Example `lw $s1, 0($s2)`

Datapath for Instruction Decode and Register File Read (ID)

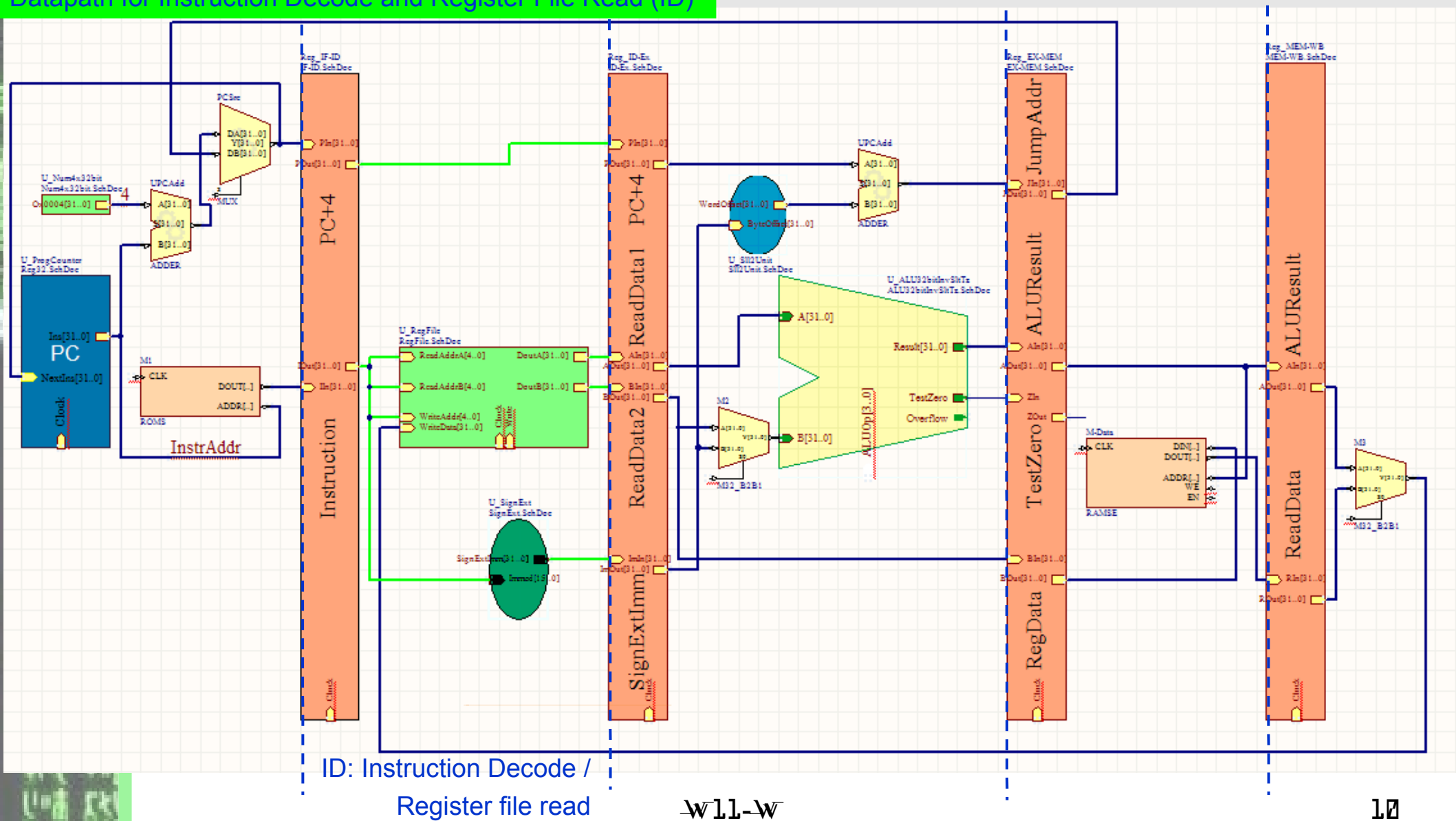

How pipelining works (3): Example `lw $s1, 0($s2)`

Datapath for Execute / Address Calculation (EX)

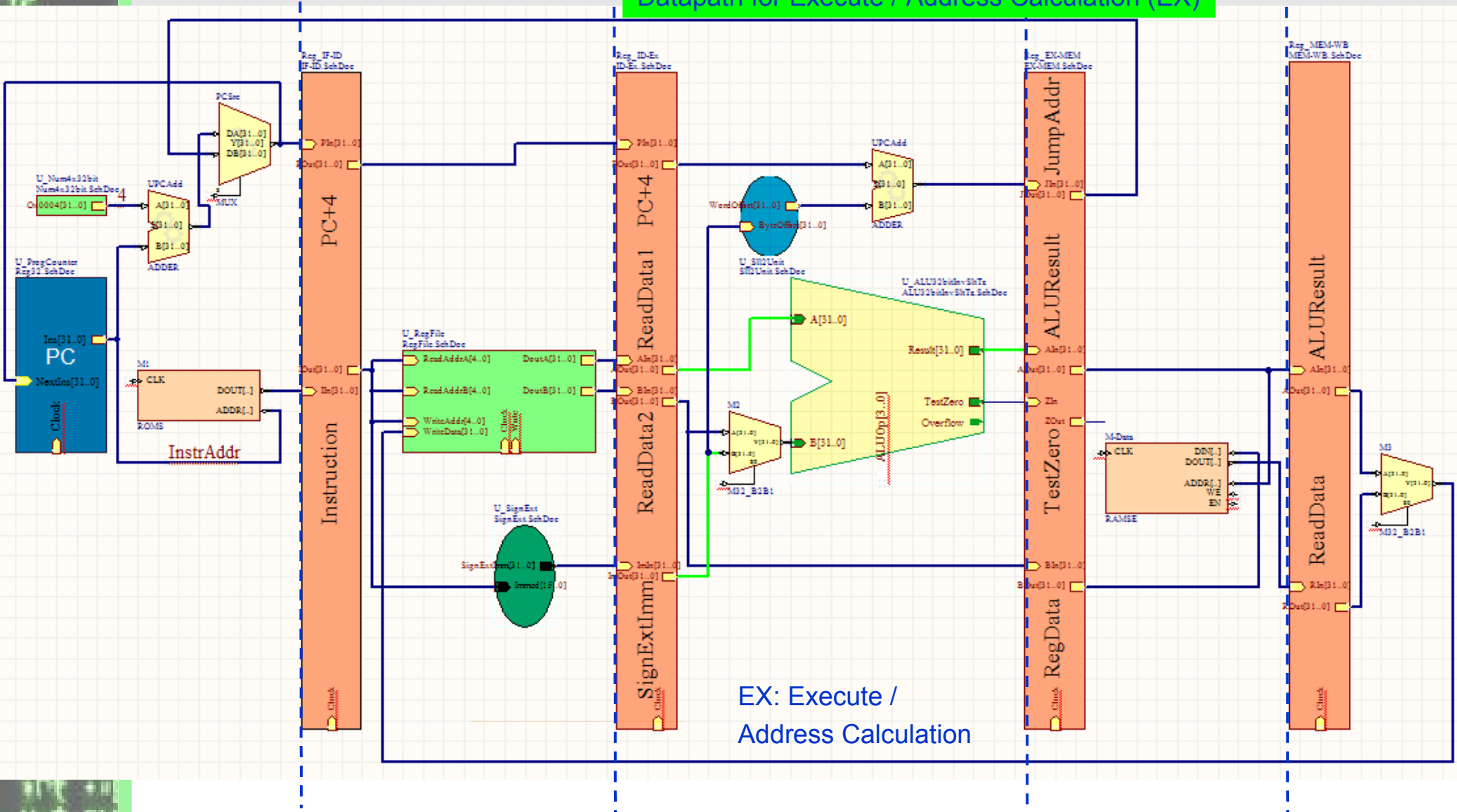

EX: Execute /
Address Calculation

How pipelining works (4): Example `lw $s1, 0($s2)`

Datapath for Memory Access (MEM)

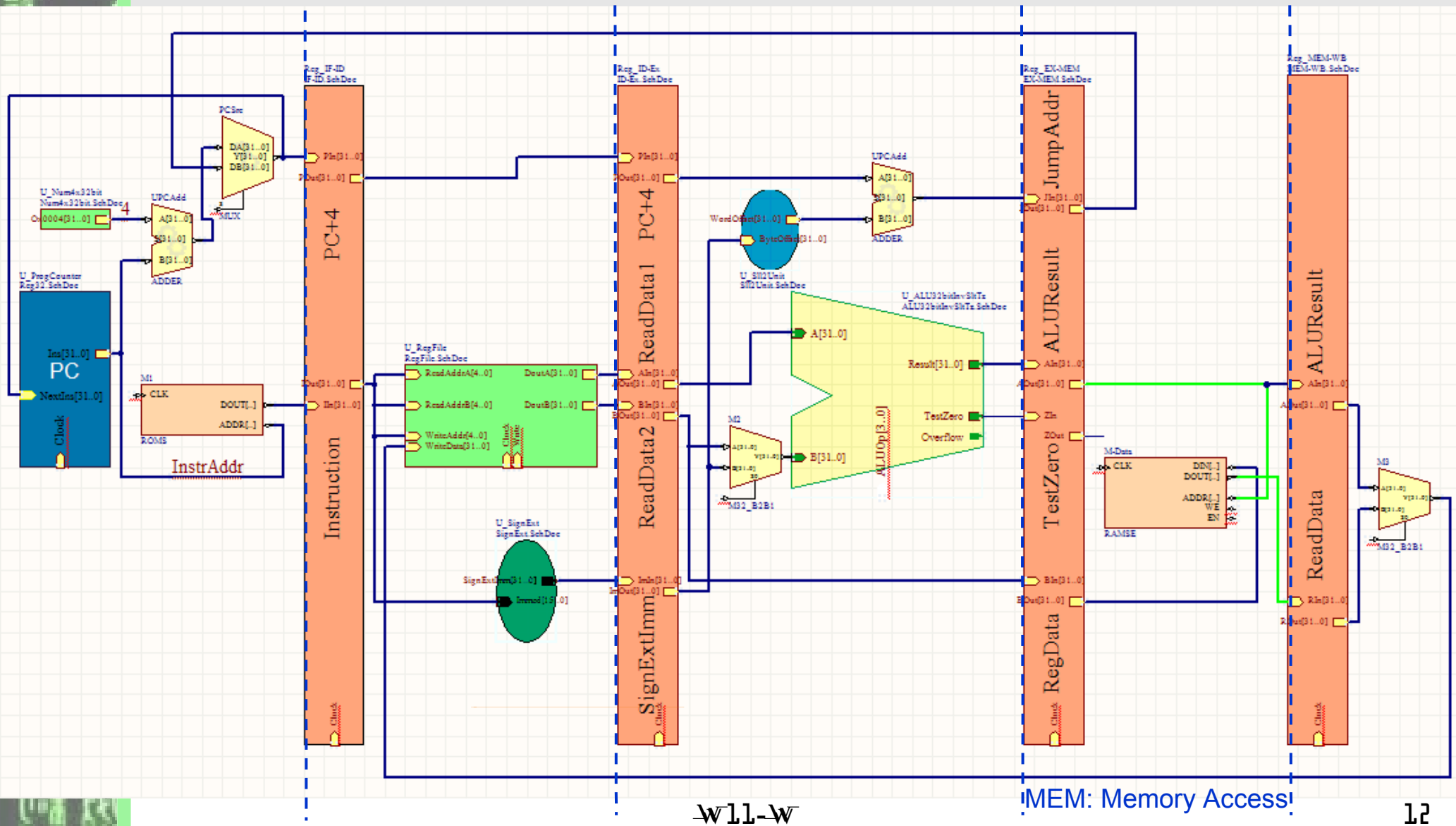

How pipelining works (5): Example `lw $s1, 0($s2)`

Datapath for Write Back (WB)

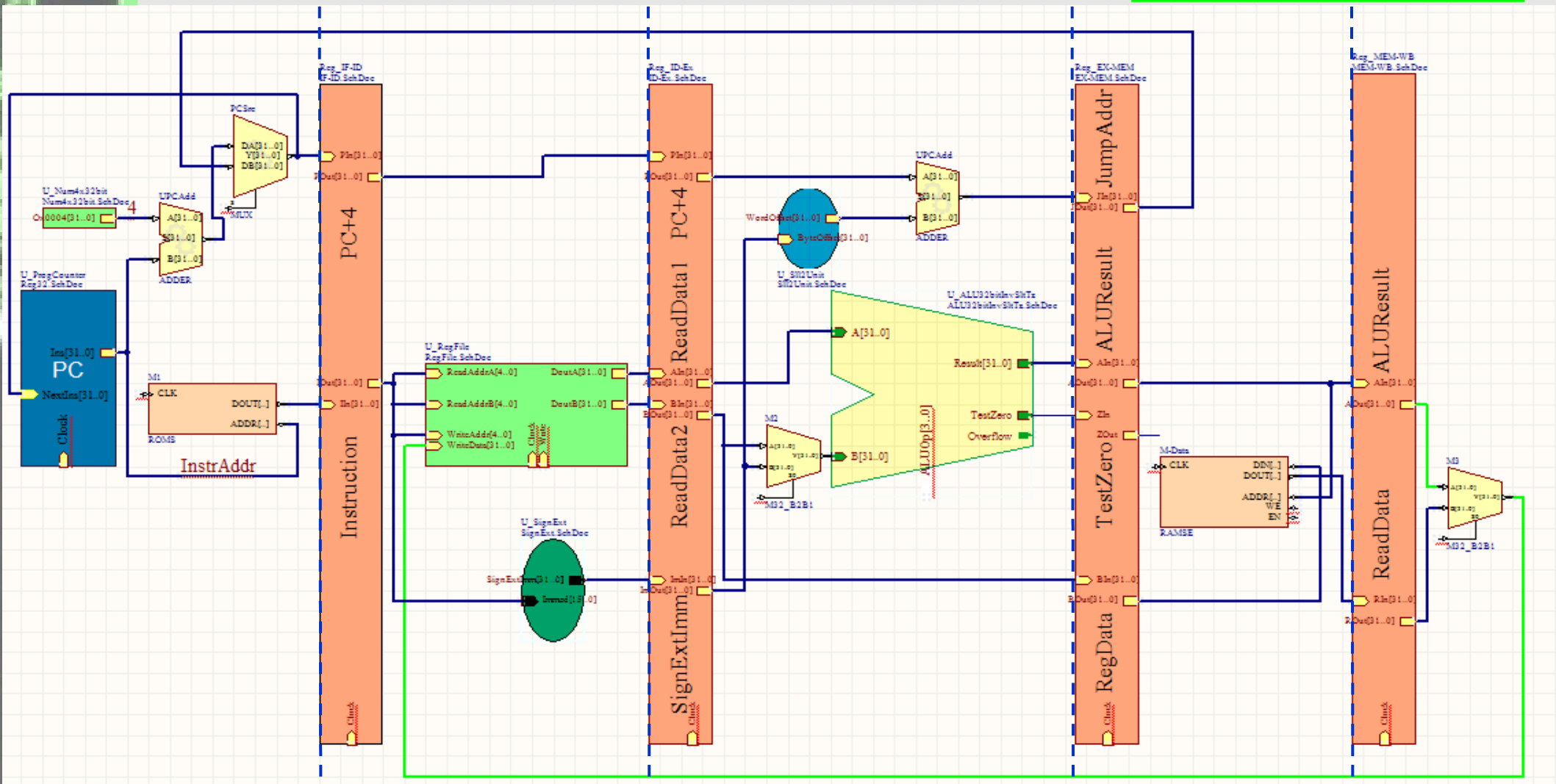

WB: Write back

How pipelining works (6): Example `lw $s1, 0($s2)`

Complete Datapath for lw instruction

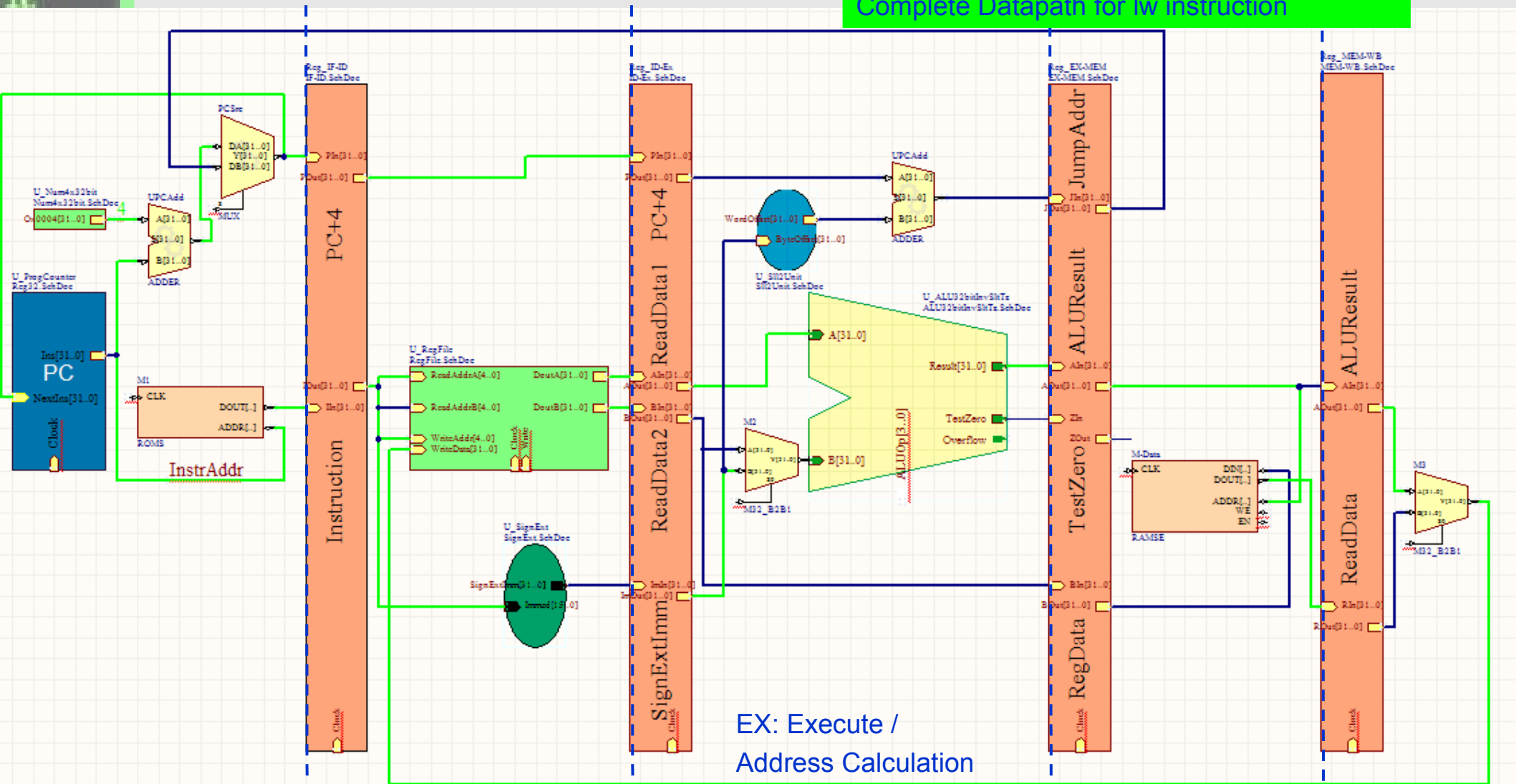

IF: Instruction Fetch

ID: Instruction Decode / Register file read

EX: Execute / Address Calculation

MEM: Memory Access! WB: Write back

W11-W

Multiple Clock Cycle Pipeline Diagram

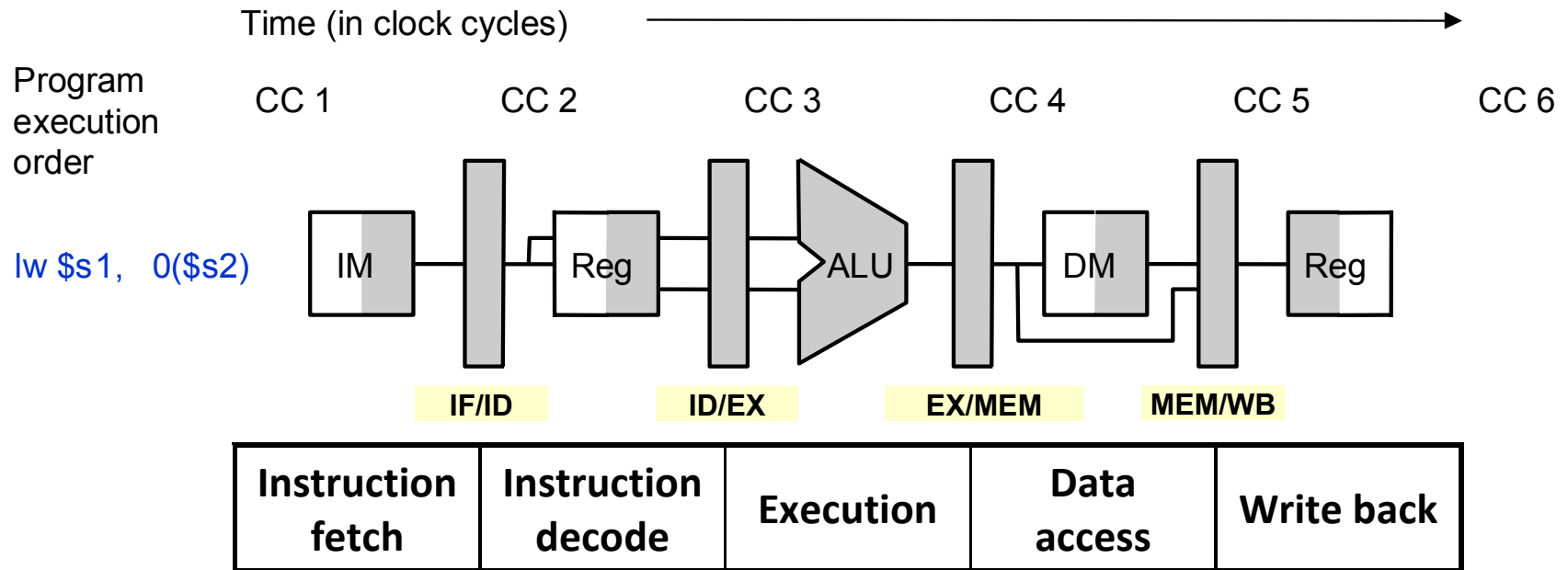

Activity 3: Using the graphical representation, show that the multiple clock cycle pipeline diagram of the following two instructions

`lw $t0, 0($t1)`

`sub $s0, $s1, $s2`

Pipelined Control (1)

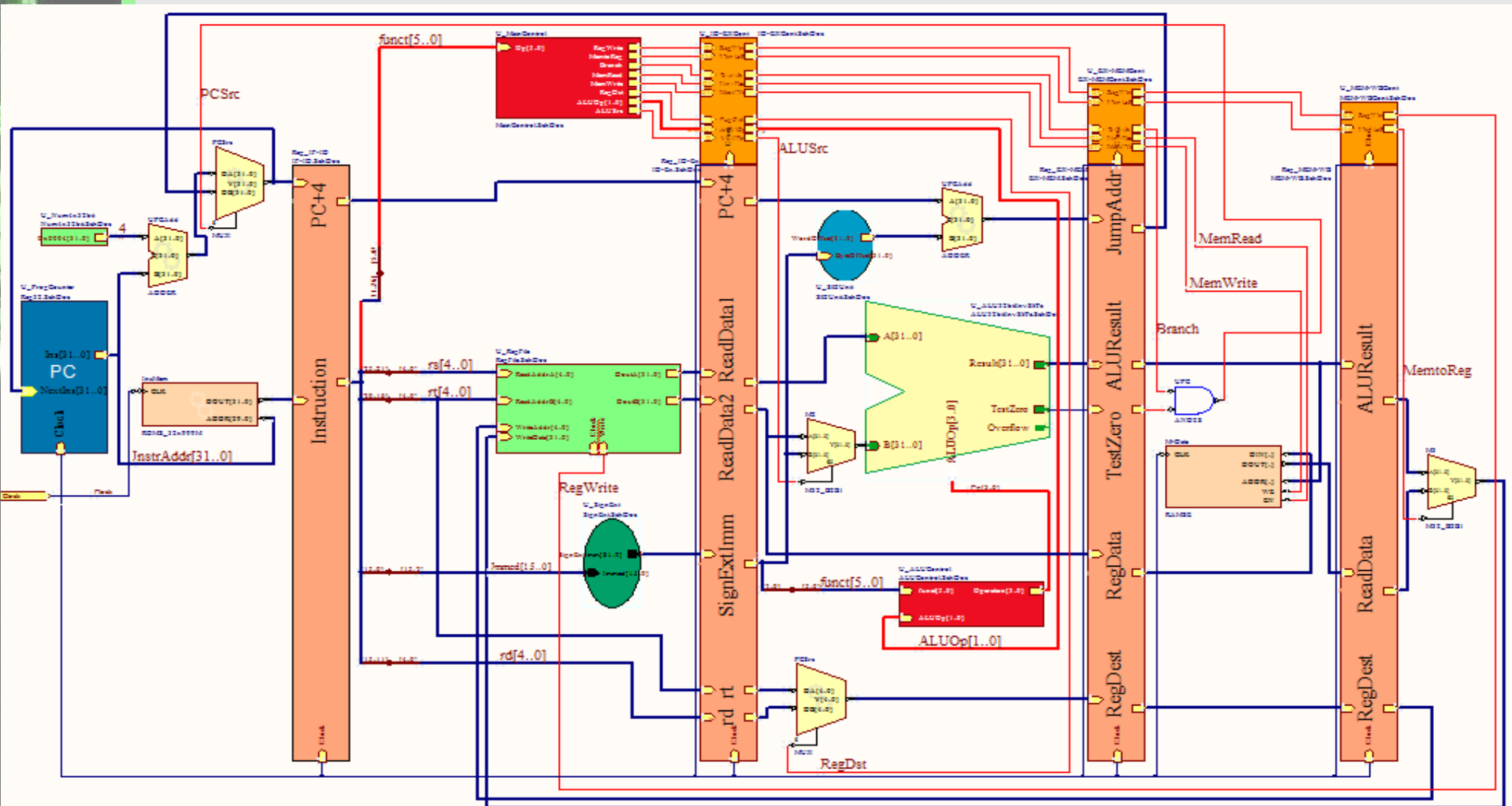

Pipelined Control (2)

- Control lines in pipelined implementation are divided into five groups according to the pipeline stage
 1. Instruction Fetch: No control needed as the “write control” of PC and “read control” of instruction memory is always asserted.
 2. Instruction Decode/Register File Read: No controls needed as the register file is being read during each instruction.
 3. Execution/Address Calculation: Control signals are **ALUSrc**, **RegDst**, and **ALUOp**.
For lw/sw instructions, **ALUSrc = 1**, **RegDst = 0** and **ALUOp = 00**. For R-type instructions, **ALUSrc = 0**, **RegDst = 1**, and **ALUOp = 10**.
 4. Memory Access: Control signals are **Branch**, **MemWrite**, and **MemRead**. For lw instruction, **MemRead = 1** and **Branch = MemWrite = 0**. For sw instruction, **MemWrite = 1** and **Branch = MemRead = 0**. For branch instructions, **Branch = 1** and **Memwrite = MemRead = 0**. For R-type instructions, **Branch = MemWrite = MemRead = 0**.
 5. Write Back: Control signals are MemtoReg. For lw instructions, **MemtoReg = 1**. For R-type instructions, **MemtoReg = 0**.
- Pipeline registers are extended to include the control signals for each stage of an instruction.

Activity 4

Show the following instructions going through the pipeline:

```
lw $10, 20($1)
```

```
sub $11,$2,$3
```

```
and $12,$4,$5
```

```
or $13,$6,$7
```

```
and $14,$8,$9
```

Activity 4: Clock Cycle # 1

IF: lw \$10,20(\$1)

ID: before<1>

EX: before<2>

MEM: before<3>

WB: before<4>

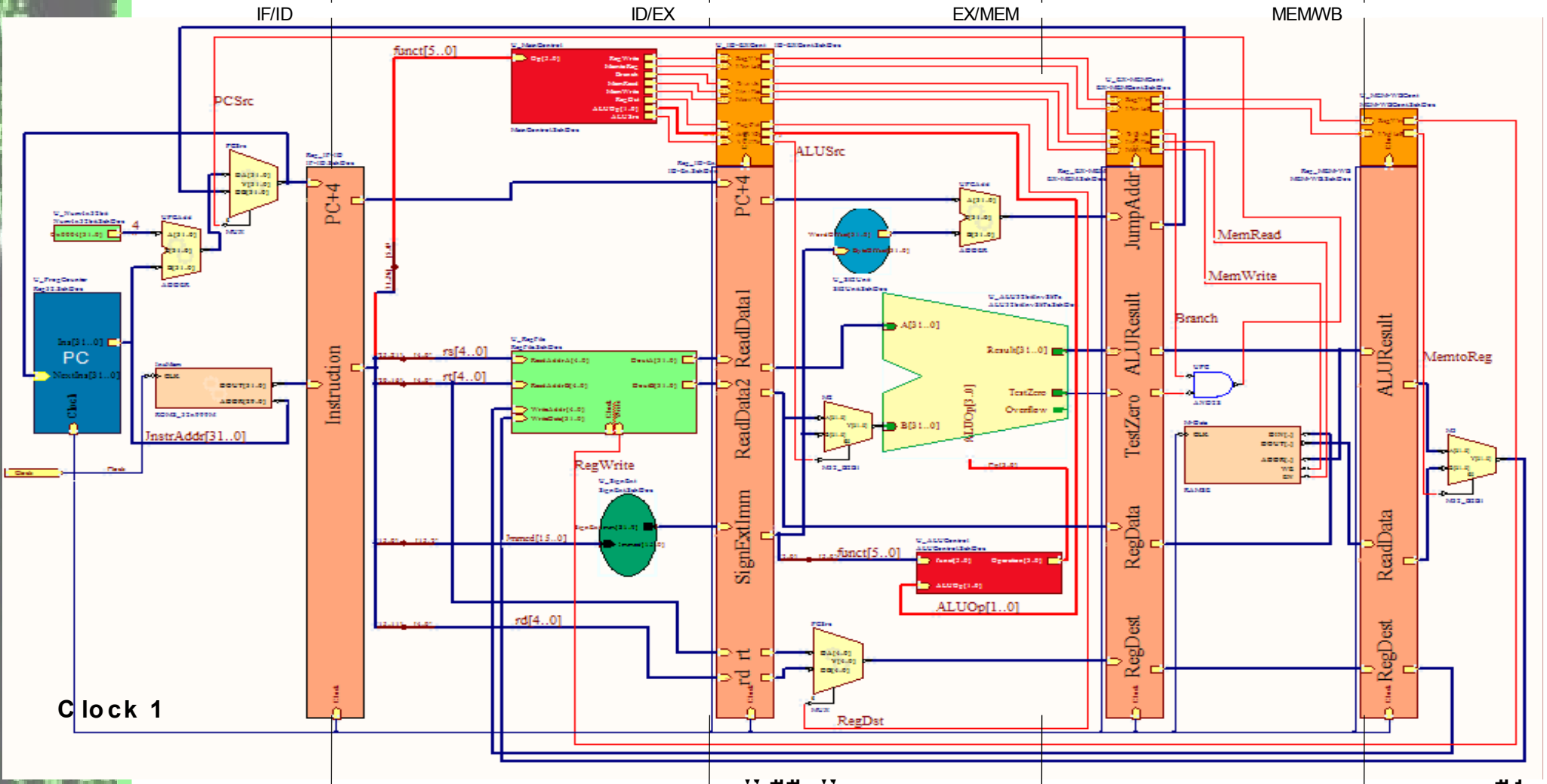

Clock 1