

# ENG2200

## Electric Circuits

Chapter 8

RLC Circuit

Natural and Step Response

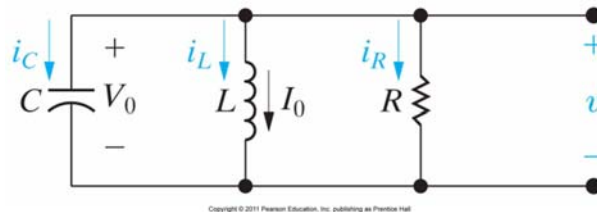
### ENG2200 Topics to be covered

- Be able to determine the natural response of RLC circuits
- Be able to determine the step response of RLC circuits.

## RLC Circuits

- The first step is to write either KVL or KCL for the circuit.
- Take the derivative to remove any integration
- Solve the resulting differential equation

### Parallel RLC circuit



KCL  
Sum of currents = 0

$$i_R + i_L + i_C = 0$$

$$\frac{v}{R} + \frac{1}{L} \int_0^t v d\tau + I_0 + C \frac{dv}{dt} = 0$$

Differentiating with respect to t, we get

$$C \frac{d^2v}{dt^2} + \frac{1}{R} \frac{dv}{dt} + \frac{v}{L} = 0$$

$$\frac{d^2v}{dt^2} + \frac{1}{RC} \frac{dv}{dt} + \frac{v}{LC} = 0$$

Solve this equation

## Parallel RLC Circuits

- How to solve this differential equation?
- We can not separate the variables like we did with the RC or RL circuits.
- Without going into a lot of Math, we claim the solution will be in the form  $v=Ae^{st}$ 
  - Exponential is the only function where high order of the derivatives have the same form (exponential)
  - First order (RL or RC) have the same form

## Parallel RLC Circuits

- Assuming  $v = Ae^{st}$  and substituting in the equation

$$\frac{d^2v}{dt^2} + \frac{1}{RC} \frac{dv}{dt} + \frac{v}{LC} = 0$$

$$v = Ae^{st}$$

$$As^2e^{st} + \frac{As}{RC}e^{st} + \frac{A}{LC}e^{st} = 0$$

$$Ae^{st} \left( s^2 + \frac{s}{RC} + \frac{1}{LC} \right) = 0$$

Either A=0 (trivial solution) or  
The quadratic part is 0

Characteristic equation

## Parallel RLC Circuits

$$s^2 + \frac{s}{RC} + \frac{1}{LC} = 0$$

$$s = \frac{-b \pm \sqrt{b^2 - 4ac}}{2a}$$

$$s_1 = -\frac{1}{2RC} + \sqrt{\left(\frac{1}{2RC}\right)^2 - \frac{1}{LC}}$$

$$s_2 = -\frac{1}{2RC} - \sqrt{\left(\frac{1}{2RC}\right)^2 - \frac{1}{LC}}$$

Both of these 2 values satisfy the equation, their sum does.

$$v = A_1 e^{s_1 t} + A_2 e^{s_2 t}$$

With a special case when  $s_1 = s_2$

The roots are determined by R, L, and C.  
The initial conditions determine  $A_1, A_2$

## Parallel RLC Circuits

$$s_{1,2} = -\frac{1}{2RC} \pm \sqrt{\left(\frac{1}{2RC}\right)^2 - \frac{1}{LC}}$$

$$s_{1,2} = -\alpha \pm \sqrt{\alpha^2 - \omega_0^2}$$

$$\alpha = \frac{1}{2RC} \text{ rad/s}, \quad \omega_0 = \frac{1}{\sqrt{LC}} \text{ rad/s}$$

Neper frequency

Resonant radian frequency

$$s_{1,2} = -\frac{1}{2RC} \pm \sqrt{\left(\frac{1}{2RC}\right)^2 - \frac{1}{LC}}$$

$$s_{1,2} = -\xi\omega_0 \pm \omega_0\sqrt{\xi^2 - 1}$$

$$\omega_0 = \frac{1}{\sqrt{LC}}, \quad \xi = \frac{1}{2R}\sqrt{\frac{L}{C}}$$

Damping ratio

## Parallel RLC Circuits

- The solution of the differential equation depends on the values of  $s_1$  and  $s_2$
- For simplicity assume  $A_1$  and  $A_2$  to be 1

$$v = A_1 e^{s_1 t} + A_2 e^{s_2 t}$$

- Consider three cases

### Overdamping $\alpha > \omega_0$ , $\zeta > 1$ -- 2 real roots

$$s_{1,2} = -\frac{1}{2RC} \pm \sqrt{\left(\frac{1}{2RC}\right)^2 - \frac{1}{LC}}$$

$$s_{1,2} = -\alpha \pm \sqrt{\alpha^2 - \omega_0^2}$$

$$\alpha = \frac{1}{2RC} \text{ rad/s}, \quad \omega_0 = \frac{1}{\sqrt{LC}} \text{ rad/s}$$

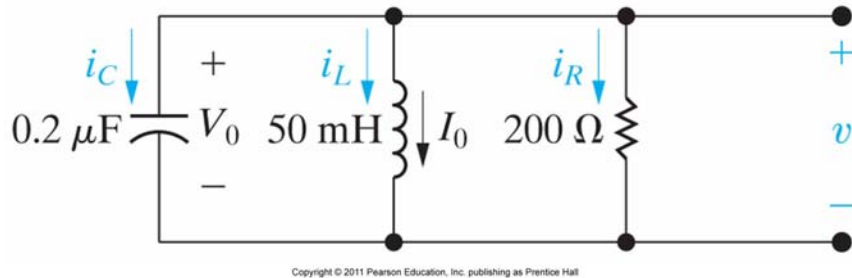
$$s_{1,2} = -\frac{1}{2RC} \pm \sqrt{\left(\frac{1}{2RC}\right)^2 - \frac{1}{LC}}$$

$$s_{1,2} = -\zeta\omega_0 \pm \omega_0\sqrt{\zeta^2 - 1}$$

$$\omega_0 = \frac{1}{\sqrt{LC}}, \quad \zeta = \frac{1}{2R}\sqrt{\frac{L}{C}}$$

$$v(t) = A_1 e^{-s_1 t} + A_2 e^{-s_2 t}$$

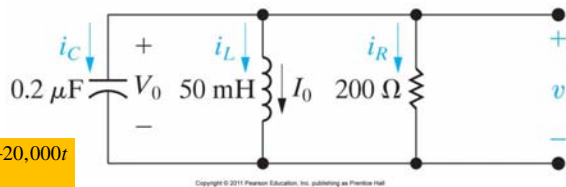
## Parallel RLC Circuits



$$v_C(0^-) = v_C(0) = v_C(0^+)$$

$$i_L(0^-) = i_L(0) = i_L(0^+)$$

## Example



$$v(t) = A_1 e^{-5,000t} + A_2 e^{-20,000t}$$

$$v(0^+) = 12 = A_1 + A_2$$

$$v(0^+) = 12 \text{ V}$$

$$i_L(0^+) = 30 \text{ mA}$$

$$i_C(0^+) = -i_R(0^+) - i_L(0^+)$$

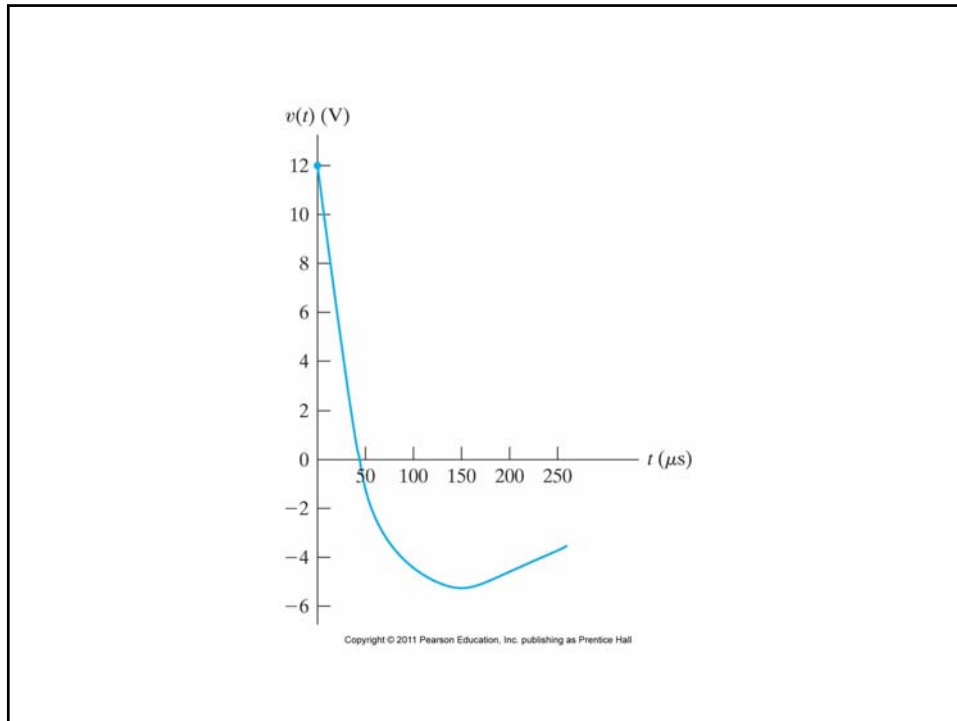
$$i_C(0^+) = C \frac{dv(0^+)}{dt}$$

$$C \frac{dv(0^+)}{dt} = -\frac{V_0}{R} - i_L(0^+)$$

$$\frac{dv(0^+)}{dt} = -\frac{V_0}{CR} - \frac{i_L(0^+)}{C}$$

$$\frac{dv(0^+)}{dt} = -450,000 \text{ V/s} = -5000A_1 - 20,000A_2$$

2 equation in 2 unknowns, solve to get A1 and A2



### Underdamping $\alpha < \omega_0$ , $\zeta < 1$

$$s_{1,2} = -\frac{1}{2RC} \pm \sqrt{\left(\frac{1}{2RC}\right)^2 - \frac{1}{LC}}$$

$$s_{1,2} = -\alpha \pm \sqrt{\alpha^2 - \omega_0^2}$$

$$\alpha = \frac{1}{2RC} \text{ rad/s}, \quad \omega_0 = \frac{1}{\sqrt{LC}} \text{ rad/s}$$

$$s_{1,2} = -\frac{1}{2RC} \pm \sqrt{\left(\frac{1}{2RC}\right)^2 - \frac{1}{LC}}$$

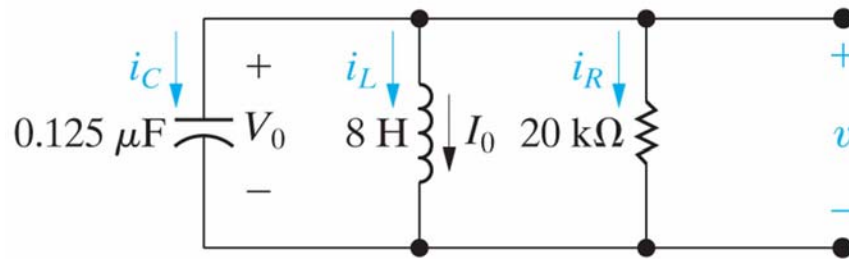
$$s_{1,2} = -\zeta\omega_0 \pm \omega_0\sqrt{\zeta^2 - 1}$$

$$\omega_0 = \frac{1}{\sqrt{LC}}, \quad \zeta = \frac{1}{2R}\sqrt{\frac{L}{C}}$$

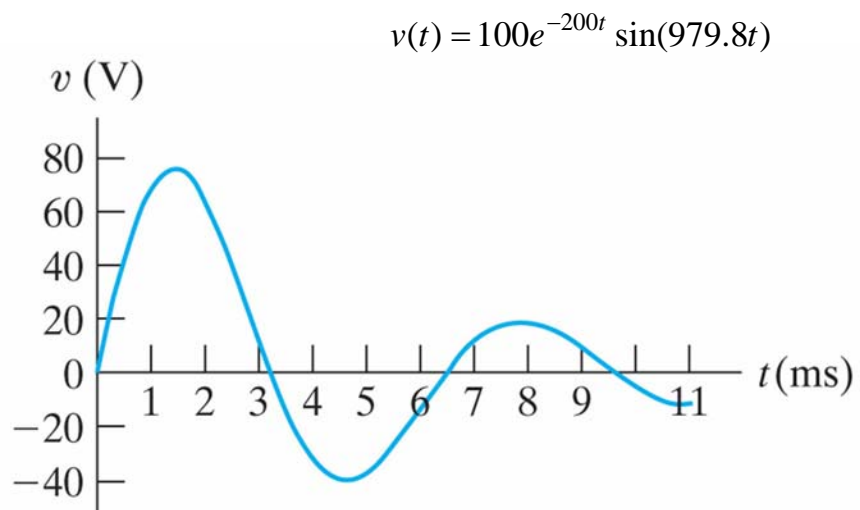
$$s = -\alpha \pm j\omega_d \quad \omega_d = \sqrt{\omega_0^2 - \alpha^2}$$

$$v(t) = B_1 e^{-\alpha t} \cos(\omega_d t) + B_2 e^{-\alpha t} \sin(\omega_d t)$$

## Example



$V_0=0$   
 $I_0=-12.25\text{mA}$





## Critically Damped $\alpha = \omega_0$ , $\zeta = 1$

$$s_{1,2} = -\frac{1}{2RC} \pm \sqrt{\left(\frac{1}{2RC}\right)^2 - \frac{1}{LC}}$$

$$s_{1,2} = -\alpha \pm \sqrt{\alpha^2 - \omega_0^2}$$

$$\alpha = \frac{1}{2RC} \text{ rad/s}, \quad \omega_0 = \frac{1}{\sqrt{LC}} \text{ rad/s}$$

$$s_{1,2} = -\frac{1}{2RC} \pm \sqrt{\left(\frac{1}{2RC}\right)^2 - \frac{1}{LC}}$$

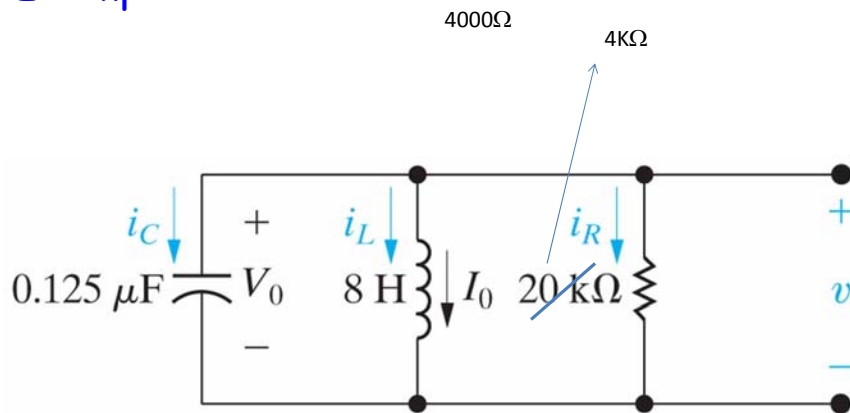
$$s_{1,2} = -\xi\omega_0 \pm \omega_0\sqrt{\xi^2 - 1}$$

$$\omega_0 = \frac{1}{\sqrt{LC}}, \quad \xi = \frac{1}{2R}\sqrt{\frac{L}{C}}$$

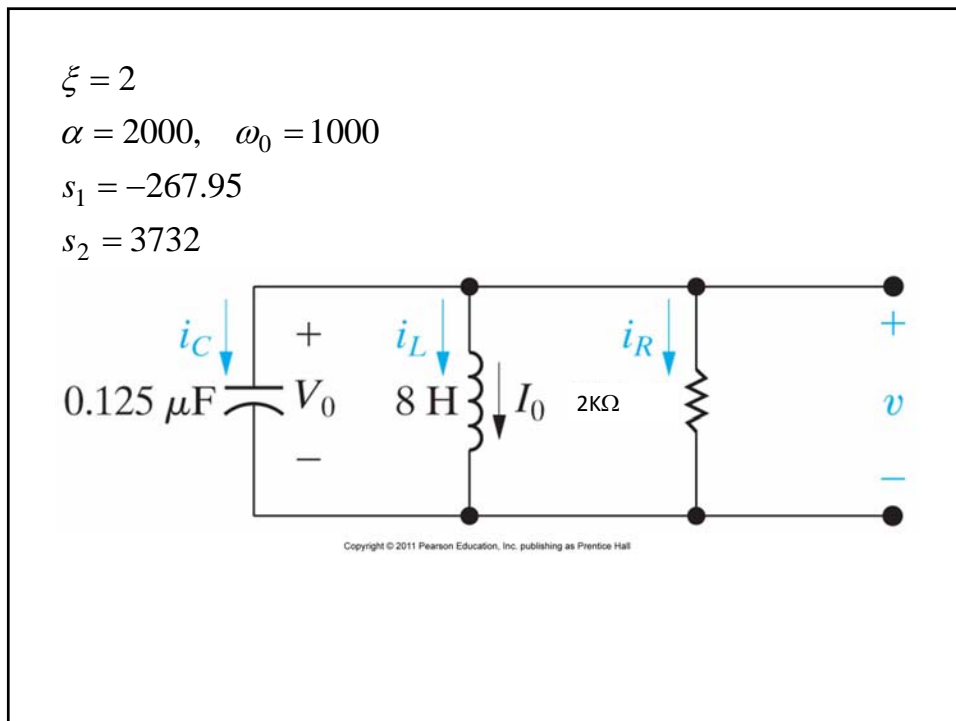
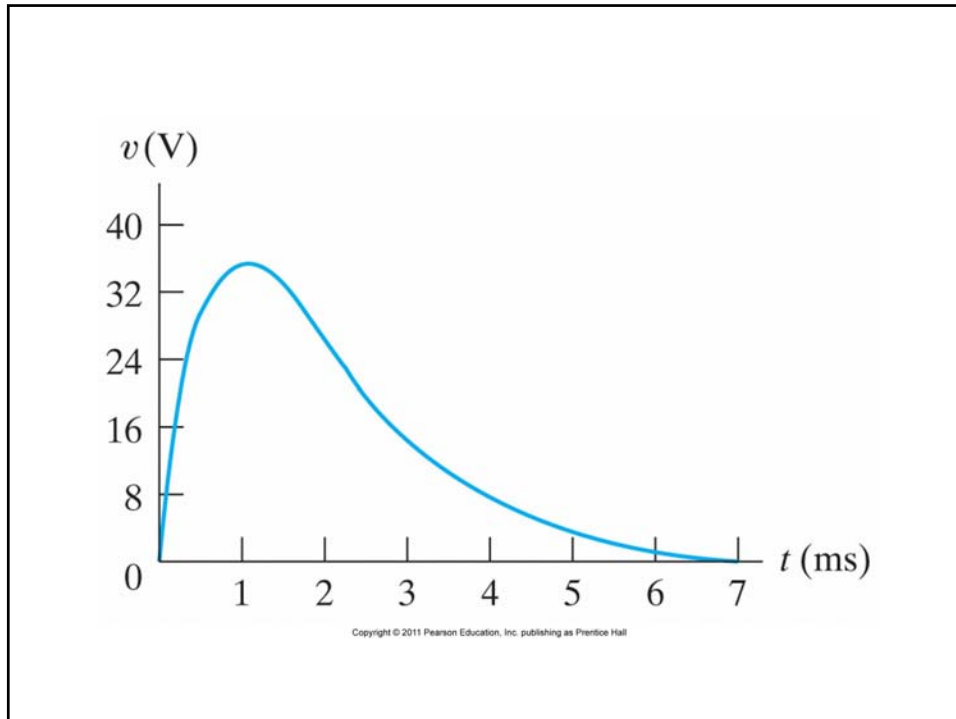
$$s_1 = s_2 = -\alpha$$

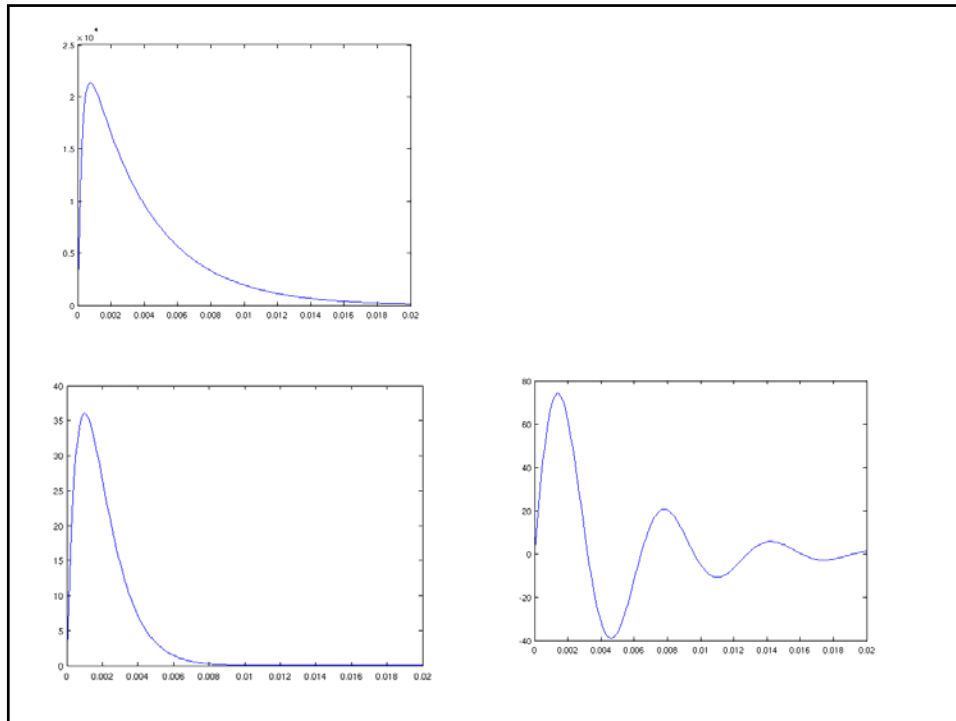
$$v(t) = D_1 t e^{-\alpha t} + D_2 e^{-\alpha t}$$

## Example



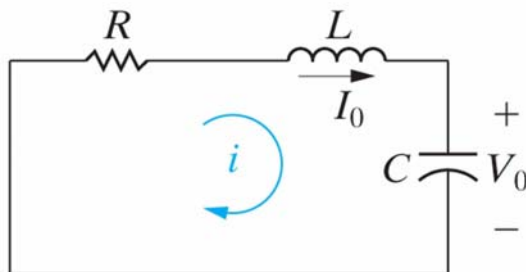
Copyright © 2011 Pearson Education, Inc. publishing as Prentice Hall





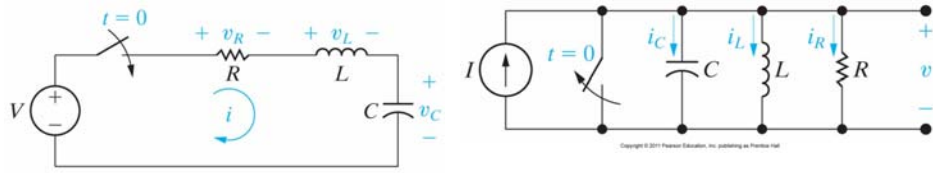
## Series RLC

- Solved in the lab manual
- Only difference is  $\alpha=R/2L$



Copyright © 2011 Pearson Education, Inc. publishing as Pearson Hall

## Step Response of RLC Circuit



$$v_L + v_C + v_R = V$$

$$L \frac{di}{dt} + v_C + iR = V$$

$$i = C \frac{dv_C}{dt}$$

$$LC \frac{d^2 v_C}{dt^2} + v_C + RC \frac{dv_C}{dt} = V$$

$$\frac{d^2 v_C}{dt^2} + \frac{R}{L} \frac{dv_C}{dt} + \frac{v_C}{LC} = \frac{I}{LC}$$

$$i_L + i_C + i_R = I$$

$$i_L + C \frac{dv}{dt} + \frac{v}{R} = I$$

$$v = L \frac{di_L}{dt}$$

$$LC \frac{d^2 i_L}{dt^2} + \frac{L}{R} \frac{di_L}{dt} + i_L = I$$

$$\frac{d^2 i_L}{dt^2} + \frac{1}{RC} \frac{di_L}{dt} + \frac{i_L}{LC} = \frac{I}{LC}$$

## Step Response of RLC Circuits

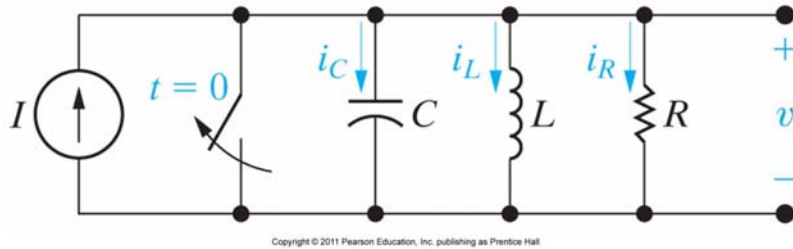
- A topic for a course in Math.
- Generally speaking, the solution of a second-order DE with a constant driving force equals the forced response plus the a response function identical to the natural response.

$$i = I_f + \left\{ \begin{array}{l} \text{function of the same form} \\ \text{as natural response} \end{array} \right\}$$

$$v = V_f + \left\{ \begin{array}{l} \text{function of the same form} \\ \text{as natural response} \end{array} \right\}$$

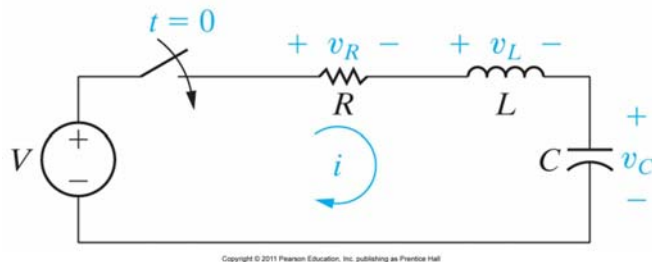
## Example

- What is the final  $I_f$

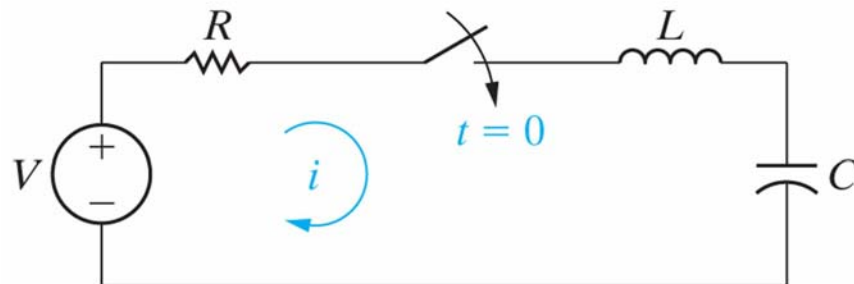


## Example

- What is the final  $V_f$



**Figure 8.4** A circuit used to illustrate the step response of a series *RLC* circuit.



Copyright © 2011 Pearson Education, Inc. publishing as Prentice Hall

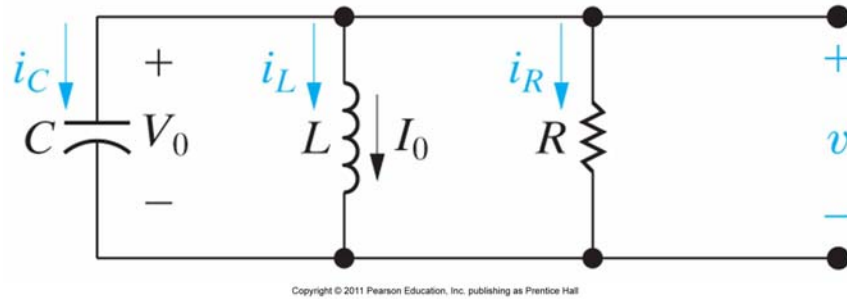
$v_c = V_f + A_1 e^{s_1 t} + A_2 e^{s_2 t}$	Overdamped
$v_c = V_f + B_1 e^{\alpha t} \cos \omega_d t + B_2 e^{\alpha t} \sin \omega_d t$	Underdamped
$v_c = V_f + D_1 e^{\alpha t} + D_2 e^{\alpha t}$	Critically damped

**TABLE 8.1** Natural Response Parameters of the Parallel *RLC* Circuit

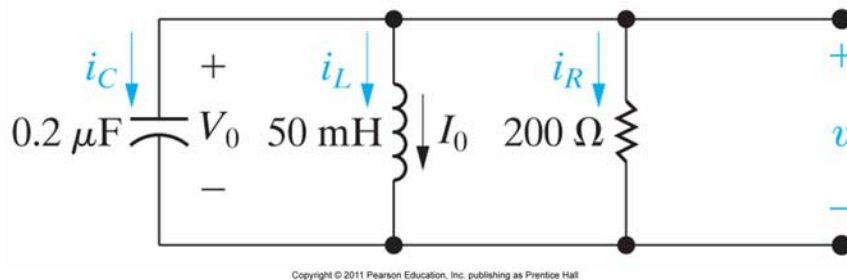
Parameter	Terminology	Value In Natural Response
$s_1, s_2$	Characteristic roots	$s_1 = -\alpha + \sqrt{\alpha^2 - \omega_0^2}$ $s_2 = -\alpha - \sqrt{\alpha^2 - \omega_0^2}$
$\alpha$	Neper frequency	$\alpha = \frac{1}{2RC}$
$\omega_0$	Resonant radian frequency	$\omega_0 = \frac{1}{\sqrt{LC}}$

Copyright © 2011 Pearson Education, Inc. publishing as Prentice Hall

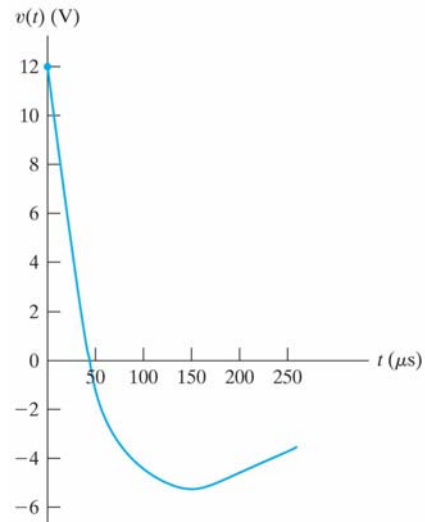
**Figure 8.5** A circuit used to illustrate the natural response of a parallel *RLC* circuit.



**Figure 8.6** The circuit for Example 8.2.

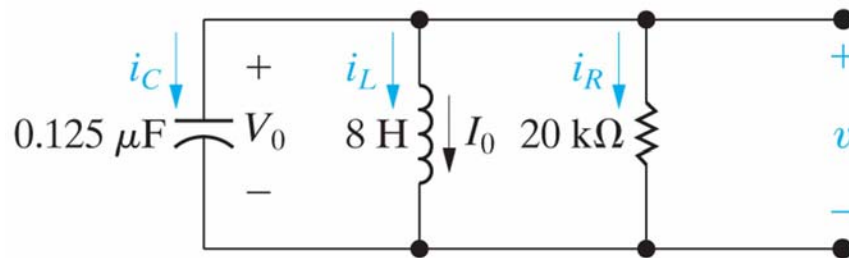


**Figure 8.7** The voltage response for Example 8.2.



Copyright © 2011 Pearson Education, Inc. publishing as Prentice Hall

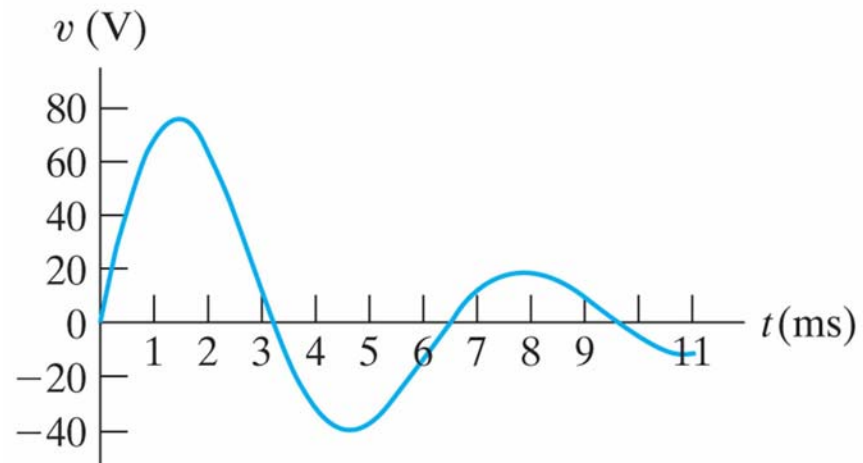
**Figure 8.8** The circuit for Example 8.4.



Copyright © 2011 Pearson Education, Inc. publishing as Prentice Hall

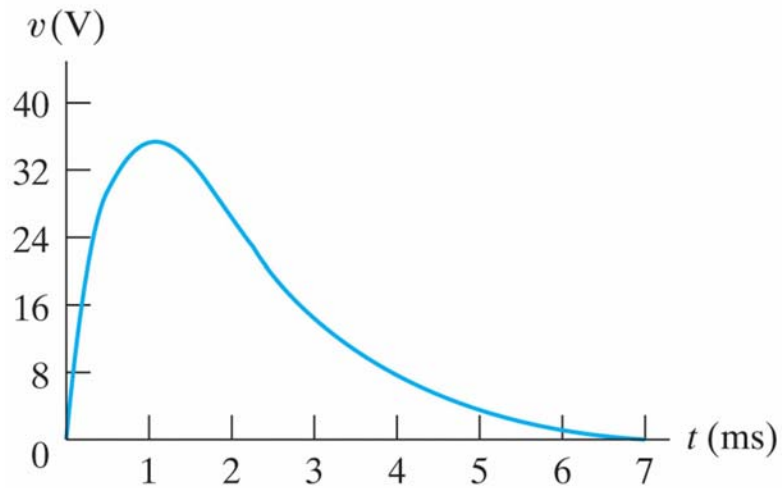


**Figure 8.9** The voltage response for Example 8.4.



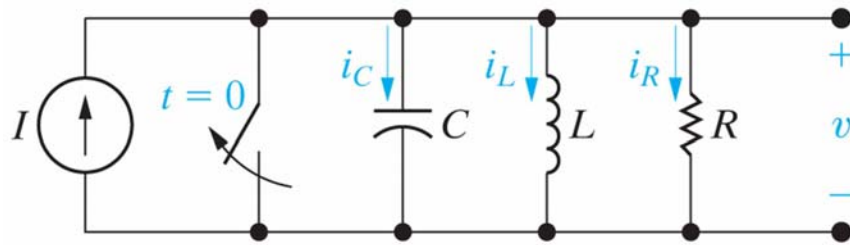
Copyright © 2011 Pearson Education, Inc. publishing as Prentice Hall

**Figure 8.10** The voltage response for Example 8.5.



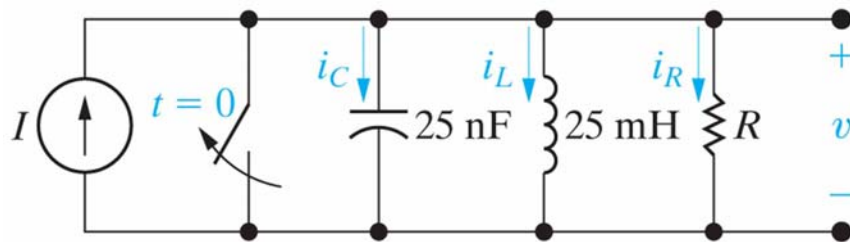
Copyright © 2011 Pearson Education, Inc. publishing as Prentice Hall

**Figure 8.11** A circuit used to describe the step response of a parallel *RLC* circuit.



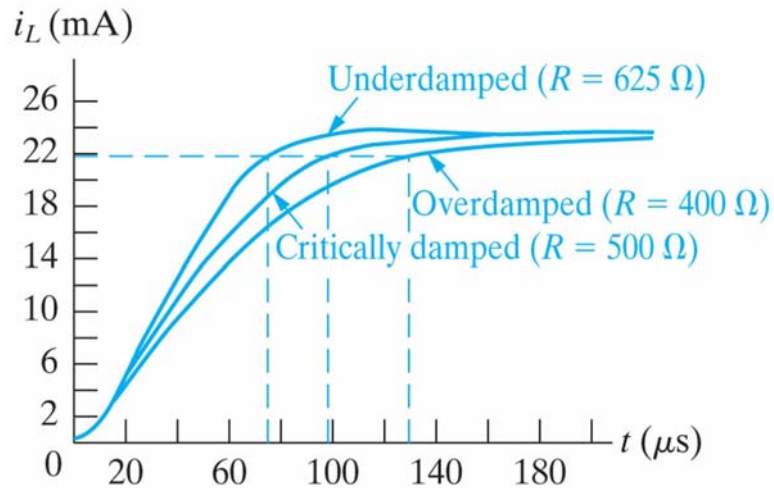
Copyright © 2011 Pearson Education, Inc. publishing as Prentice Hall

**Figure 8.12** The circuit for Example 8.6.



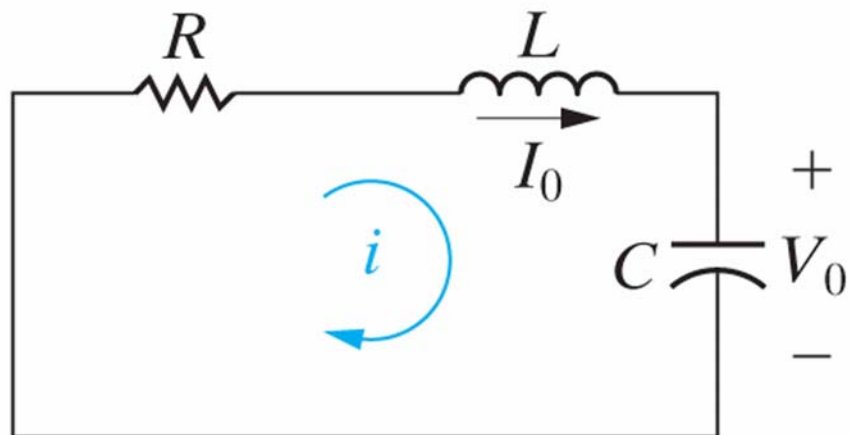
Copyright © 2011 Pearson Education, Inc. publishing as Prentice Hall

**Figure 8.13** The current plots for Example 8.9.



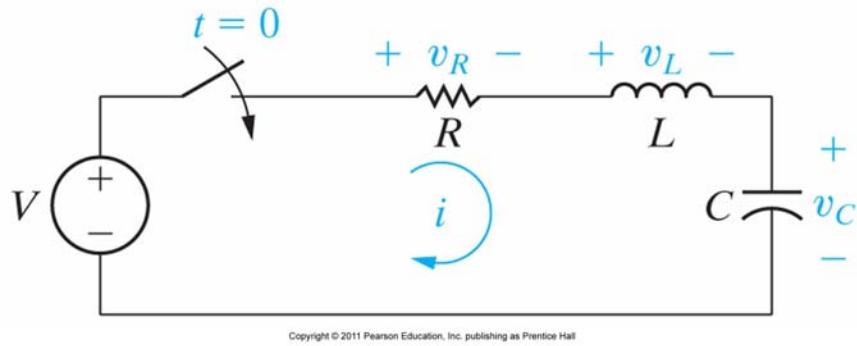
Copyright © 2011 Pearson Education, Inc. publishing as Prentice Hall

**Figure 8.14** A circuit used to illustrate the natural response of a series *RLC circuit*.

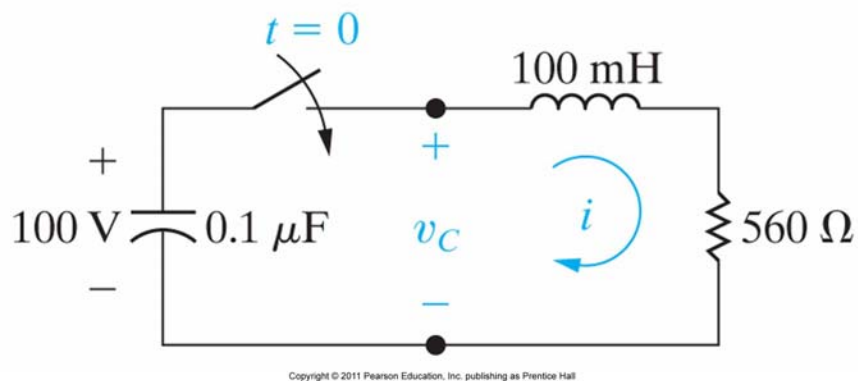


Copyright © 2011 Pearson Education, Inc. publishing as Prentice Hall

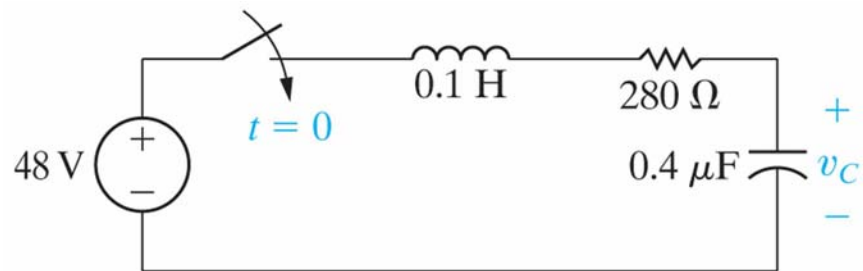
**Figure 8.15** A circuit used to illustrate the step response of a series *RLC* circuit.



**Figure 8.16** The circuit for Example 8.11.



**Figure 8.17** The circuit for Example 8.12.



Copyright © 2011 Pearson Education, Inc. publishing as Prentice Hall